

myschlick.com



Living for Solutions:  
Model 937. We cover it all.



Homogeneous spray and maximum coverage for fluidised bed applications

## Flexible: For a wide range of surface coverage

Fluidised bed applications demand a variety of requirements in terms of spray behaviour. E. g., if the application requires a nozzle for a fine, homogeneous spray, which can also be used to wet large surface areas, then the SCHLICK 937 multi-head system is the perfect choice. The external-mix two-substance 937 nozzle allows independent control of the flow rate and fineness of the atomisation. For hard-to-access working areas, SCHLICK offers the individually calibrated spray-unit of the 937 series. A spraying system that consists of a specially produced media-connector and the pharma nozzle itself. Individually manufactured for your application, e.g. top spraying.







Your application. Our nozzle.

## Custom-made. Spray units matched to your system.

Nowadays, production systems differ significantly in their design, and thus increasingly call for spray systems with customised connections. The reason lies in the often hard-to-access work areas. To address this issue, SCHLICK designed the pharma spray-unit. In combination with the pharma nozzle 937, it is available in many different versions and is designed or adjusted to each individual application. For the 937-series spray-unit, the media-connector is securely connected to the pharma nozzle. For example via thread, clamp connection or push-in connector. Customised solutions are also available.

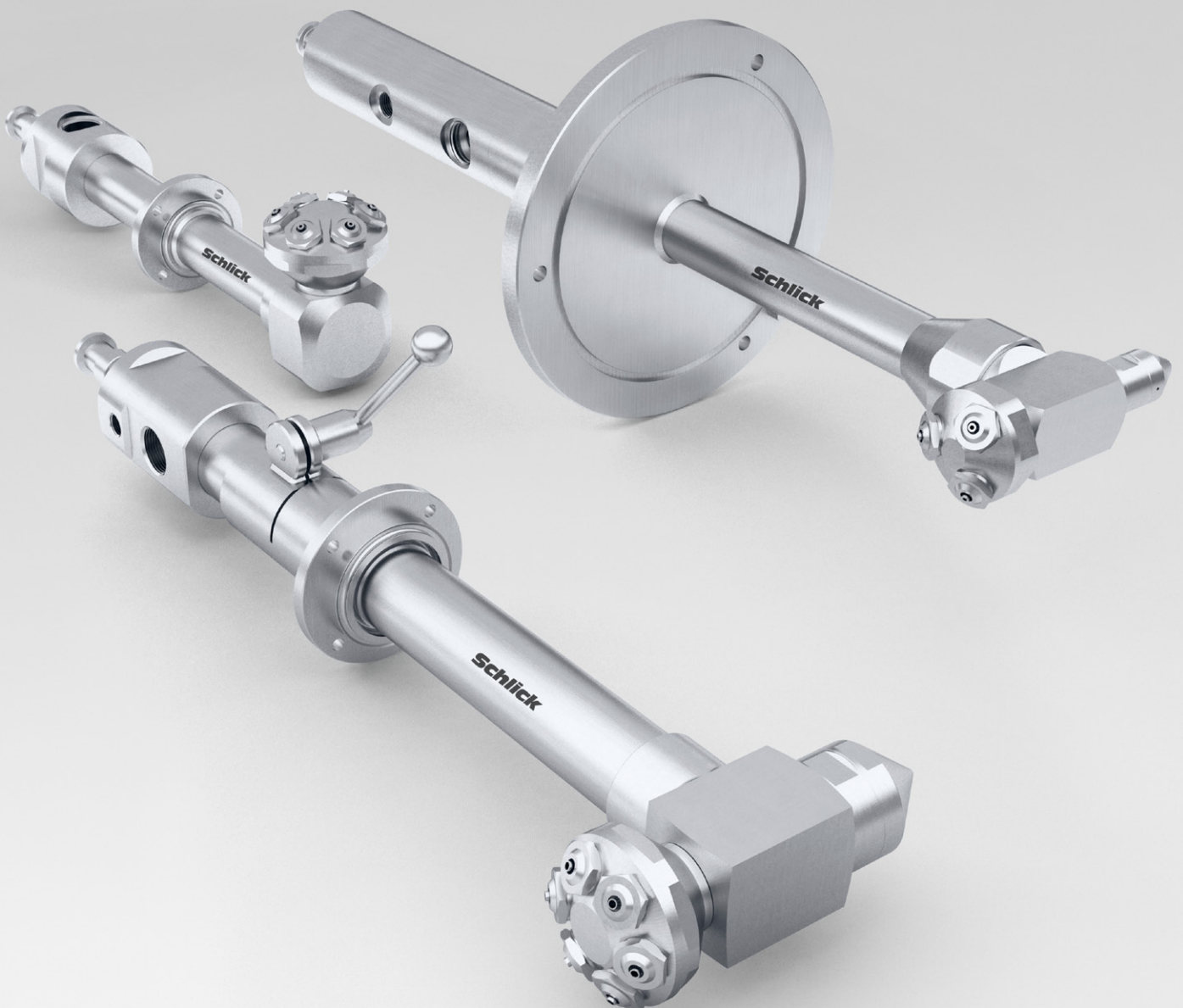



## Variable. The perfect spray angle for any application.

SCHLICK produces its 937 multi-head systems in three sizes. These can be combined with various nozzle heads. Nozzle heads generally have three or six heads. The 3-head version has 45° and 60° spray angles as standard. The 6-head version has 60° and 90° spray angles. Special designs such as 7-head variants or those with different spraying angles are available on request. The option to use nozzle heads with different spraying angles ensures the best possible coverage for small to very large surfaces, depending on the requirements.

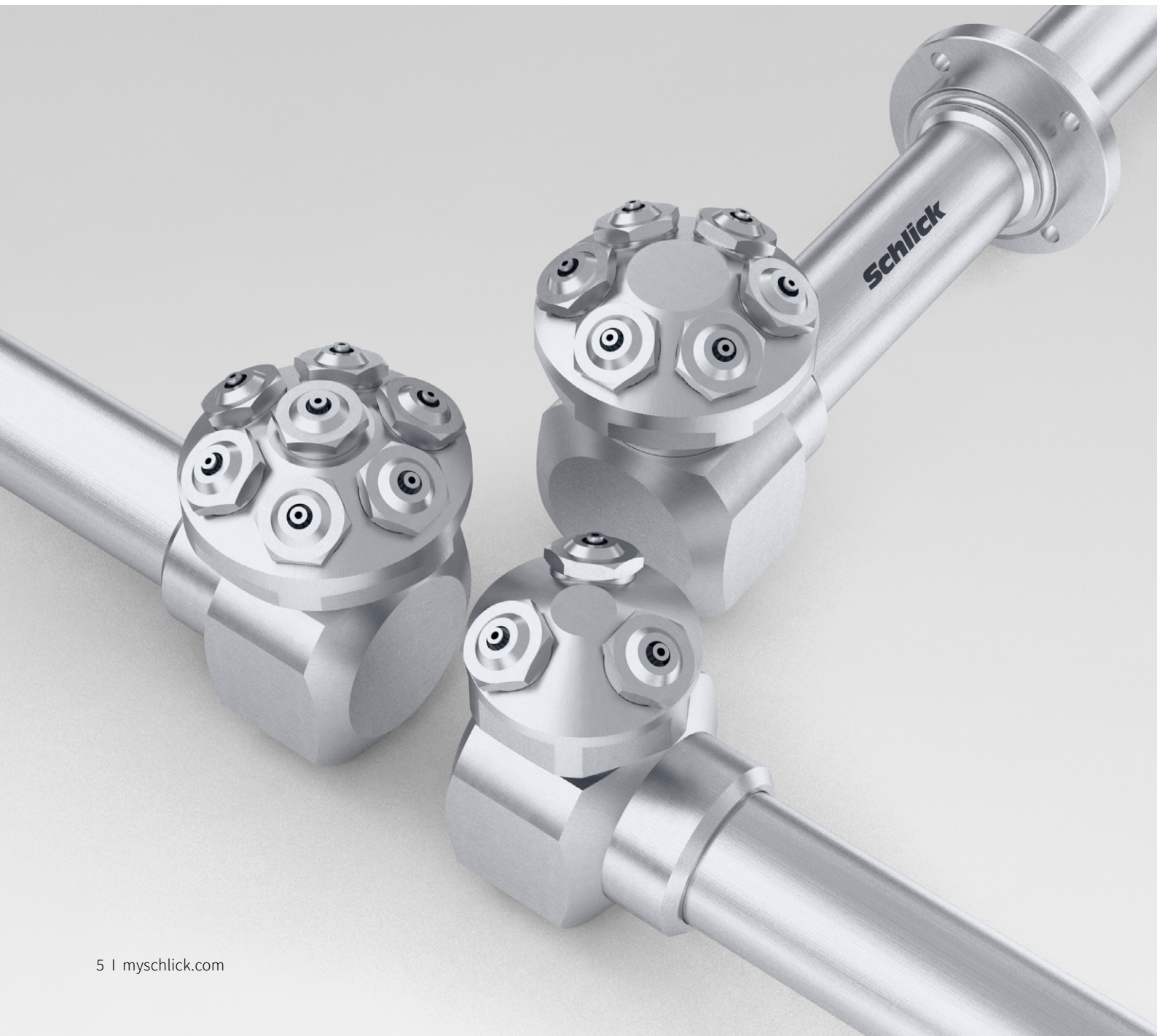

## Modular. Straightforward and easy handling.

It's often the little things that make all the difference. The 937 system series can be easily fitted with extensions in next to no time. These help to optimise the spray on the one hand, and avoid caking at the air outlet on the other. With the right combination of nozzle head – namely the number of nozzles fitted and the spray angle – and the option to use extensions, there are innumerable product variants that you can rely on to optimise your applications.



3 nozzles with extension

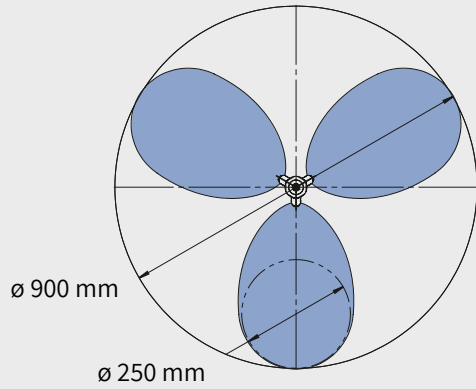
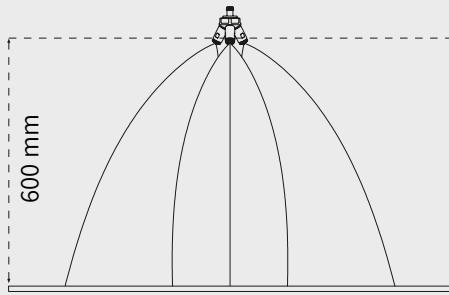

3 nozzles without extension

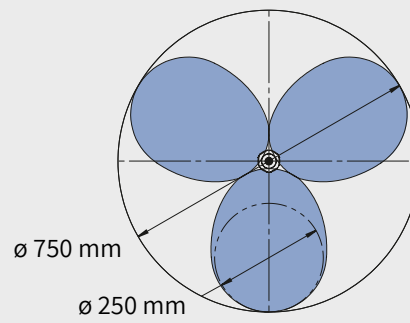
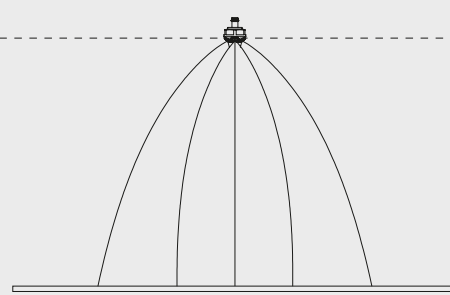

6 nozzles with extension

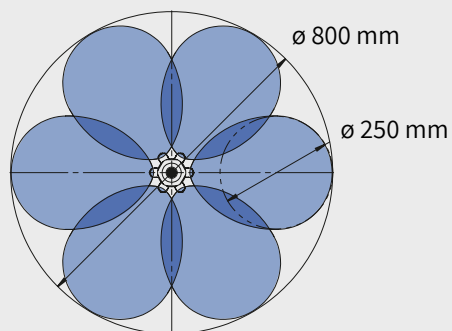
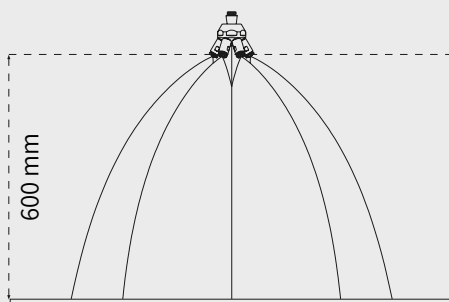

6 nozzles without extension

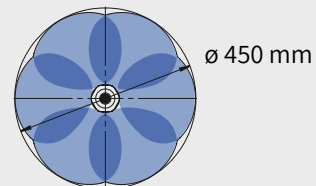
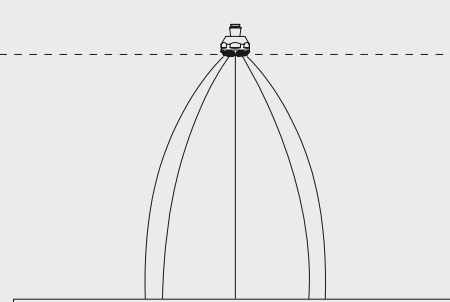

Spray diameter with and without extensions, shown on model 937/7-1 S1, 60°

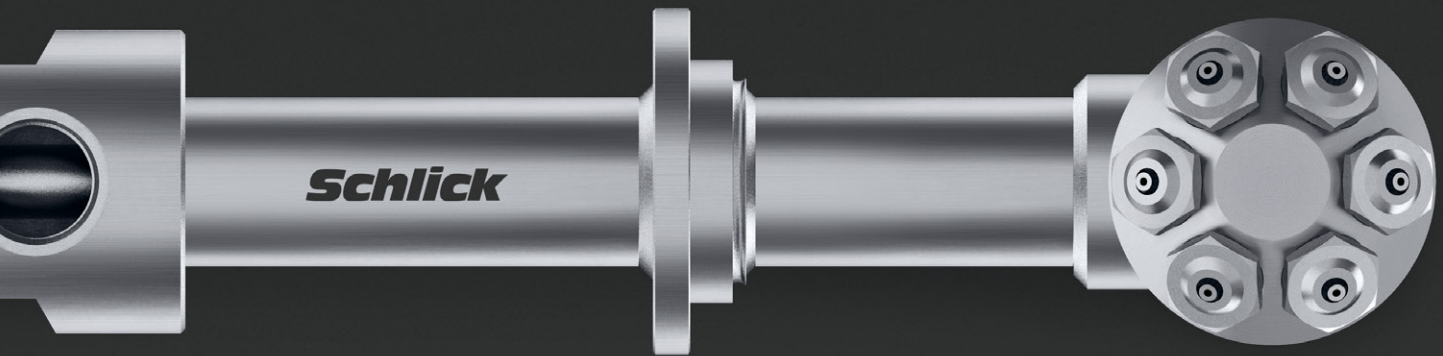

## Benefits of the 937 model version at a glance

### Optimal spray result

Extremely homogeneous spray behaviour with maximum surface coverage.

### Extremely efficient

The multi-head system especially for producing extremely wide spray cones.

### Safe handling

Simple installation/ de-installation for cleaning or servicing by hand.

### Maximum flexibility

Optimal flexibility thanks to straightforward installation/ de-installation and conversion of nozzle.

### Simple cleaning

A sophisticated nozzle structure makes cleaning work significantly easier.

### Wide scope of application

The different model variants allow for a wide range of surface coverage.

### Highly adaptable

Suitable shaft lengths are produced according to customer specifications and requirements.

### Variable spraying angle

The different nozzle heads provide spraying angles of 45°, 60° and 90° as standard.

### Spray optimisation

Special extensions for the nozzle head optimise the spray behaviour.



# Guaranteed identical spray quality

The spray quality of the tried-and-tested SCHLICK model 937 stands out thanks to its extremely homogeneous spray behaviour with maximum surface coverage. This has been investigated and confirmed using laser optics at the SCHLICK Test & Research Centre.

The following spray parameters were checked here:

**liquid flow, flow of the atomisation medium, spray angle, droplet size, droplet speed and droplet size distribution.**

## Droplet size distribution

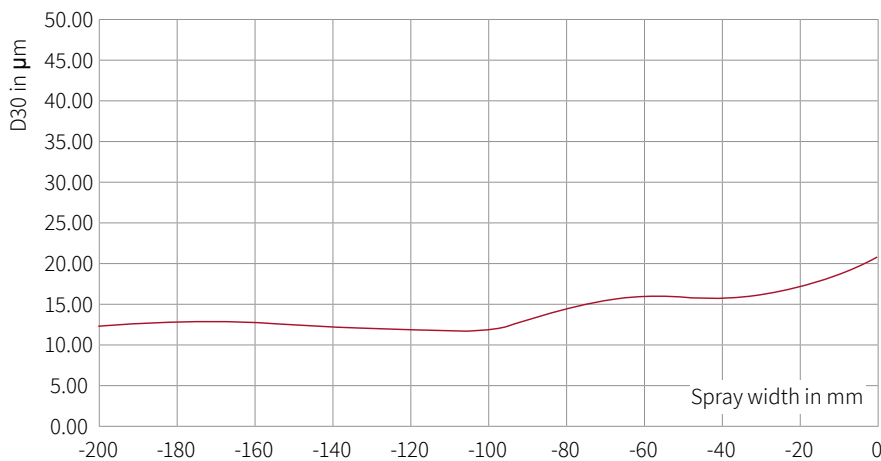

### Operating conditions

**(Water, reference liquid):**

Water: 30 l/h

Air pressure: 2 bar (g)

Distance to measuring volume: 150 mm

Measuring points: 11

Increment: 20 mm

Measuring time: approx. 45 mins

## Speed distribution

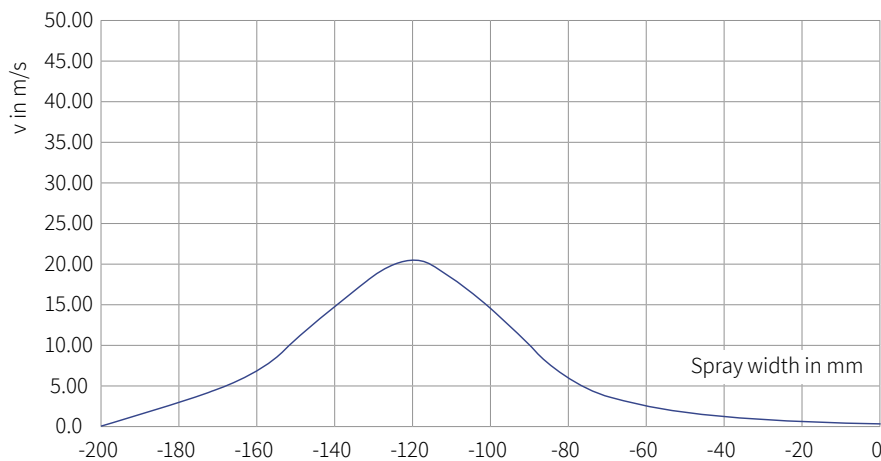

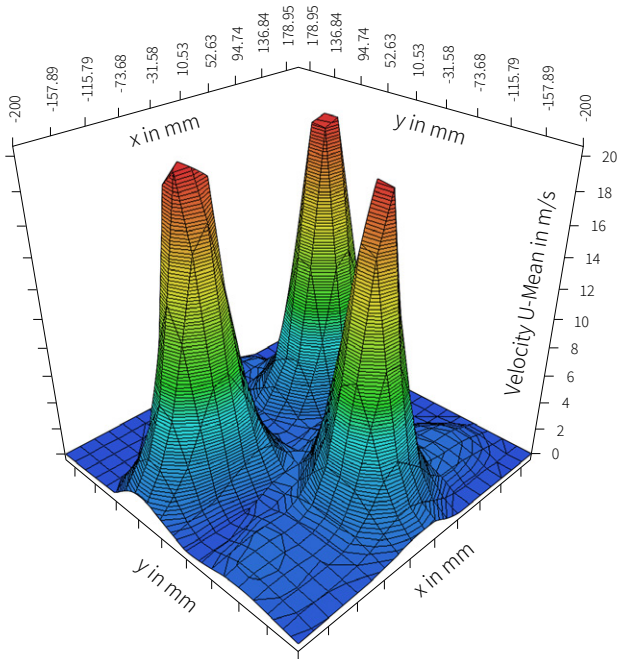

Speed distribution of the spray head in the spray direction

The fact that the peaks in speed are exactly the same height demonstrates the production quality of the 937 model. Despite there only being one pump head, the liquid is atomised evenly into the system via three openings.

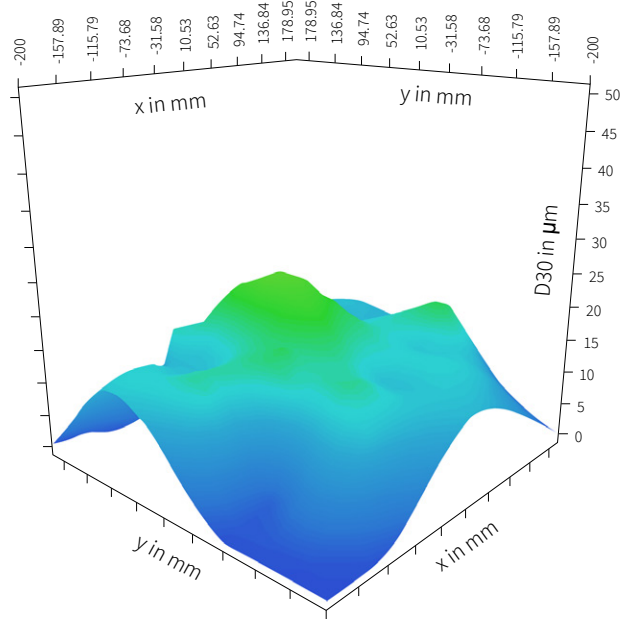

Droplet size distribution across the spraying surface

The graphic shows a consistently homogeneous droplet size distribution despite the difference in speed between the three openings and the spraying area, as is represented in the previous graphic.

Mass flow distribution  
= volume/surface area/time unit

The volume flow distribution immediately in front of the nozzle. An even distribution of liquid, which provides maximum homogenisation when applied to the product.

**Operating conditions**  
**(Water, reference liquid):**  
 Water: 30 l/h  
 Air pressure: 2 bar (g)  
 Distance to measuring volume: 150 mm  
 Measuring points: 241  
 Angle increment: 30°  
 Increment: 10 mm

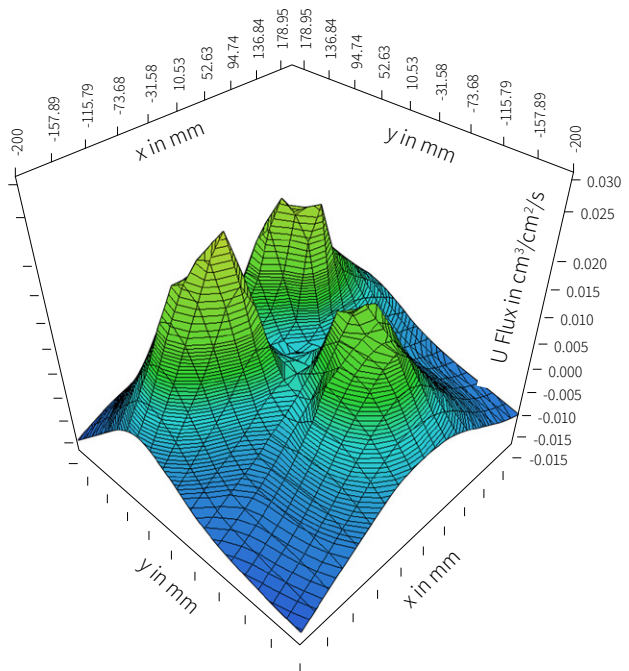

Your application. Our nozzle.  
Our promise: Living for solutions.

**Consultation, engineering, production and testing.**

At SCHLICK, you get everything from one source.

The ideal solution for your application.

**Phone** +49 9565 9481-0

**Mail** [info@myschlick.com](mailto:info@myschlick.com)

Subject to technical alterations . 09.2022



Düsen-Schlick GmbH  
Hutstraße 4  
96253 Untersiemau/Coburg  
Germany  
Tel.: +49 9565 9481-0

[www.myschlick.com](http://www.myschlick.com)  
[info@myschlick.com](mailto:info@myschlick.com)